

The Reported Shape, Size, Kinematics, Electromagnetic Effects, and Presence of Sound of Unidentified Aerial Phenomena from Select Reports, 1947-2016

Robert M. Powell¹, Larry Hancock¹, Laiba Hasan², Sarah Little¹, Robinson Truong²,
Tobi Kamoru²

¹Scientific Coalition for UAP Studies, Town Lake Dr., Ste A, #173, Fort Myers, Florida

²University of Toronto, 1 King's College Circle, Toronto, Ontario M5S 3H2

Submitted: March 21, 2023

Revised: September 26, 2023

Published: December 7, 2023

Robert Powell  <https://orcid.org/0000-0001-7449-2499>

Correspondence regarding this article should be addressed to Robert Powell.

Email: exploringSCU@gmail.com

ABSTRACT

Publicly available witness reports, catalogued by military and civilian agencies, of Unidentified Aerial Phenomena (UAP) from 1947 to 2016 were hand-sorted for selection based on four criteria: reliability of witness testimonies, object angular size greater than 0.15 degrees, sufficient lighting, and sufficient information detail. The resultant database comprises the subset of historical UAP reports that were determined to likely represent unidentified aerial objects. Out of more than 100,000 reports amassed from one military database and four civilian databases, 301 reports spanning the same years were identified as meeting these criteria. From this selected set, the characteristics of shape, size, kinematics, electromagnetic effects, and sound emanation are examined. Detailed descriptions in the witness accounts allowed us to present scaled illustrations for the two most common UAP shape categories: disks (domed, elongated, shortened) and triangles (isosceles, equilateral). The largest shapes reported were diamond/rectangle and boomerang (median 300 ft (91 m)), and the smallest were spheres (median 20 ft (6 m)). Triangles (median 170 ft (52 m)) were consistently reported to hover, did not produce electromagnetic effects, and were often noted to have an absence of sound. The combination of unusual kinematic range and absence of sound was found in 16 reports which specifically mentioned objects that hovered, travelled faster than Mach 1, and exhibited an absence of sound: disk (5), triangle (8), oval (1), sphere (1), and boomerang (1). The dataset of UAP characteristics presented here, based on 301 reliable witness reports, can be used to inform the design of the various UAP field instrumentation, detection algorithms, and propulsion hypotheses that are critical to the advancement of our understanding of UAP.

Keywords: UAP, UAV, UFO, Unidentified Aerospace Phenomena, Unidentified Aerial Phenomena, Unidentified Anomalous Phenomena, UAP shapes, UAP database

1 Introduction

1.1 UAP Reporting History

The modern era of UAP reports coincided with aerial combat during the Second World War and originated with sightings by allied fighter pilots of balls of light that followed their planes. Pilots soon dubbed these “foo fighters” (CIA, 1953). The U.S. Air Force began to study the phenomenon in 1948, first with Project Sign, then Project Grudge, and then Project Blue book from 1953-1969 (USAF, 1995). The term Unidentified Flying Objects (UFOs) was adopted in 1952 (Ruppelt, 1956). This term has been used off and on with its first documented usage in a January 31, 1949, memo from Strategic Air Command to the Director of the FBI. The term UAP is the new replacement for UFO. UAP was used in 1999 with the formation of the National Aviation Reporting Center on Anomalous Phenomena (NARCAP, 2023) and also appears in the UK’s Condign report in 2000 (UKMoD, 2000). The formalization of the term was driven by Jay Stratton, the head of the UAP Task Force in 2020. The acronym UAP is still with us as of this writing, although the word connected to the “A” has variously been “aerial,” “aerospace,” “aerospace-undersea,” and now rests at “anomalous.” A useful scientific taxonomy for UAP research has yet to be developed.

In this paper, we will use the term “UAP report” to refer to a report by a witness describing an object in the sky that the witness did not recognize. The term “UAP event” will refer to the description and circumstances surrounding the sighting of an anomalous aerial phenomenon at a specified timeframe and location. The term “UAP case” will refer to the collection of data related to the event. The term “UAP” will be reserved for an object, described by one or more witness and sensors, whose case, despite being examined and investigated by independent researchers, remains unexplained.

UAP reports have been catalogued in publicly available historical databases by military organizations in many countries: the United States (1947-1969; USAF, 1995; ESD, 2023); the United Kingdom (1950-2008; UKMoD, 2000); Brazil (1952-1986; Brazil, 2022); Canada (1952-1979; Hayes, 2020); Australia (1952-1983; Tott, 2013); and New Zealand (1952-2009; NZDF, 2010). France’s database (1977-present) is unique in that it is the result of investigation of the phenomenon by the French civilian space program (GEIPAN, 2023; Swords et al., 2012).

Military organizations have primarily driven the analysis of UAP reports within their own databases. However, as national security is a more pressing concern than explaining all UAP events, a small subset of UAP events whose reported behaviors resist explanation has been left unresolved. In the past, this has been justified by the military of some countries, including the United Kingdom, the U.S., France, Australia, and Spain by concluding that the phenomenon was not a threat to national security (Swords et al., 2012; UKMoD, 2000). This view may be changing. In June of 2021, the U.S. Director of National Intelligence issued a report that indicated there was a potential threat to national security by UAP (ODNI, 2021), and acknowledged that worldwide reports of these unknown objects continue to this day (ODNI, 2023).

UAP reports have also been collected and catalogued by U.S. civilian agencies including, for example: Aerial Phenomena Research Organization (APRO; 1952-1988; Clark, 1998), National Investigations Committee on Aerial Phenomena (NICAP; 1956-1980; Hall, 1994), Center for

UFO Studies (CUFOS; 1973-2002; CUFOS, 2002), Mutual UFO Network (MUFON; 1969-present; MUFON, 2023), and the National UFO Reporting Center (NUFORC; 1974-present; NUFORC, 2023).

Non-profit organizations and private individuals have driven the creation and analysis of UAP reports for these civilian databases. Very much like the military databases, each of these databases contains a small subset of UAP events whose reported behaviors resist explanation with no conclusive resolution as to their cause or origin.

Our dataset is created with a high-quality and information-rich selection of these perplexing and unresolved cases from military and civilian databases.

1.2 UAP Report Data Quality

Both military and civilian studies that seek to obtain information about the frequency, location, or characteristics of UAP, using raw databases of UAP sighting reports, have encountered the same data quality problems for 70 years. The three primary UAP data quality problems are misidentification, insufficient data, and hoaxes.

Misidentification: Hendry, 1979, found that 91% of all UAP reports were readily explainable. The reports represented either astronomical objects (e.g., stars, planets, meteors, aurora borealis), man-made objects (e.g., aircraft, balloons, drones, paper lanterns), or flying animals (e.g., birds, bats, insects). USAF, 1955, found that 69% of all reports described known, identifiable objects, and an analysis of Project Blue Book's database collected by the military from 1947-1969, determined that 94% of the reports were of identifiable objects (USAF, 2022).

Insufficient data: In some cases, there was not enough information in the UAP report to make a reasonable determination as to whether the object witnessed might have a prosaic explanation. Hendry, 1979, found 3% of all reports to have insufficient information, and USAF, 1955 found 11% insufficient.

Hoaxes: Hoaxes made up a small percentage of UAP reports (Hendry, 1979). USAF, 1955 determined that less than 2% were hoaxes.

In summary, it is likely that 90% or more of all UAP reports are either identifiable objects, hoaxes, or contain insufficient information. For our study, we address this problem by selecting unresolved reports based on the reliability of observations, nearness of objects, sufficient lighting, and sufficient information (see section 2.2).

1.3 Historical Shape Analysis

The long-standing problem of assigning shapes to witness descriptions of UAP is exemplified by Gindilis et al., 1979. When working with 256 unfiltered reports from the former Soviet Union from 1925 to 1976, the research team created ten shape categories for spheroids (e.g., star-like, spherical, disks, crescents, elongated), each with two subcategories (e.g., stars, stars of noticeable volume; regular sphere, deformed sphere); six "exotic" shape categories (e.g., triangle, rectangle); four "irregular" categories (e.g., irregular spot, dumbbell); the category of "changing shape;" and two more catchall categories (e.g., "difficult to determine"). The authors finished their report with, "Of course, this classification is arbitrary."

Despite the difficulties with assigning shapes to UAP reports, there have been many past efforts to catalogue the many UAP shapes (Truettner & Deyarmond, 1949; USAFd, 1955; NICAP, 1964; Ballester-Olmos, 1976b; Gindilis et al., 1979; UKMoD, 2000, Johnson & Saunders, 2002; Teodorani, 2009; Dittman & Rutkowski, 2014). A summary of these efforts is presented in Table 1. In many cases, neither these studies nor their databases were published in peer-reviewed journals. Therefore, the total shape percentages are only approximate, having been inferred from the hand-drawn and mimeographed charts, graphs, and witness descriptions that we found available online.

Table 1

Historical Analysis and Shape Summaries of Various Databases, 1948-2013

Reference	Years	Report count	Data source	Region	Were the reports filtered?	Predominant ($\geq 5\%$) shape categories approx. %
Truettner & Deyarmond, 1949	1948-1949	203	Project Sign	Primarily U.S.	No	Sphere 27% Disc 25% Oval 11% Cylinder 10%
USAF, (Battelle) 1955	1947-1952	3200	Project Blue Book	Primarily U.S.	Yes	Elliptical 45% Rocket, aircraft 8% Lenticular, cone, teardrop 5%
NICAP, 1964	1942-1963	575	NICAP	Primarily U.S.	No	Disc 26% Round 17% Oval 13%
Ballester-Olmos, 1976b	1932-1975	200	Ballester-Olmos, Vallee	Spain and Portugal	Landings	Lens 11% Disk 7%
Gindilis et al., 1979	1925-1976	256	Gindilis et al.	U.S.S.R.	No	Crescent 25% Starlike 21% Disk 15% Elongated 7%
UKMoD, 2000	1987-1997 (1959-1997) ^a	2780 (9449) ^a	U.K. govt	U.K.	No	Ball 30% Triangle 7% (Disk 2%)
Johnson & Saunders, 2002	1947-2002	146,000	UFOCAT 2002	Global	Unknown	Disk 62% Ball 5% Light 5%
Teodorani, 2009	1949-2009	5369	NUFORC, Hudson Valley	Ontario, New York, Connecticut	No	Starlike 13% Disk 7% Triangle 8% Oval 5%

Dittman & Rutkowski, 2014	1989-2013	14,541	Private and govt orgs.	Canada	No	Starlike 50% Sphere 15% Disk 10% Triangle 10% Cylinder 5%
AARO, 2023; U.S. Senate, 2023	1996-2023	650	Unknown	Global	Unknown	Orb, round, sphere 47% Lights 16% (Disk 2%)

Table 1. Summaries of the results of historical shape analyses of UAP witness report databases from around the world listed chronologically. Only the shape categories that comprised at least 5% of the respective reports are listed here. In order that there is one common shape category, if possible, across the studies represented here, the disk percentage of 2% is included for UKMoD and AARO. USAF, 1955, did not have a disk category. Most analyses were performed on a raw, unfiltered database, that is, high quality reports were not specially selected for analysis; or the method for selecting reports was not described. ^a The total UKMoD dataset; only the years 1987-1997 (2780 reports) were used for their shape analysis.

Some UAP reports contain witness drawings (Ballester-Olmos, 1976b), but these also are varied, ranging from simple disks with domes and rectangles to bulb shapes with round lights and odd craft with protruding appendages. Others catalogue ten different shapes that all present as circular from at least one viewing angle (NICAP, 1964).

The Canadian study of 14,541 unfiltered reports from 1989-2013 (Dittman & Rutkowski, 2014) assigned the following categories: triangles (including V's), boomerangs (including crescents, U's and wedges), spheres (including balls and orbs), discs (including circles, donuts, rings, round, and saucers), cylinders (including bars, barrels, bullets, capsules, cigars, and pencils), fireballs, point sources, other (including things like hexagons, swords, boxcars, winged craft, etc.)

A quick glance at the historical efforts (Table 1) shows the confusion in shape nomenclature that immediately obfuscates useful quantitative analysis, e.g., is a “ball” the same thing as a “sphere”? Is a “disk” the same thing as a “lens”? Could all three be the same shape from different views? This ambiguity caused by the orientation of the object with respect to the witness affects the reported shape and continues to make comparison studies problematic.

Despite the difficulty in determining consistent shapes for the many different types of UAP reports, such a study is a critical first step towards developing a working taxonomy. Shape classification can help focus appropriate instrumentation tied to site selection to increase the likelihood of obtaining more definitive measurements of reported characteristics. It can also help inform training sets for AI search algorithms of satellite and ground-based image data.

We have created a collection of UAP reports that are most likely to represent *unidentified aerial objects*. From this, we present a dataset of UAP shapes as they relate to size, kinematics, electromagnetic effects, and sound emanation.

2 Methodology

2.1 Primary Databases

There were five primary databases, one military and four civilian, that were relied upon as a source of raw UAP reports for this paper (links are provided in the Data Accessibility section):

1. Project Blue Book (1947-1969) was the U.S. Air Force database (USAF, 1970)
2. NICAP (1956-present) is a civilian group that collects UAP reports of note
3. CUFOS (1967-2002) is a civilian database (CUFOS, 2002) amassed from multiple collections
4. MUFON is a civilian database (MUFON, 2023) of publicly submitted paper files (1970-1999) and electronic files (2000-present)
5. The GEIPAN database

We chose not to include the NUFORC database (NUFORC, 2023) due to its lack of prescreening and its significant overlap with MUFON's database. Our amassed collection represents over 100,000 reports from the years 1947-2016.

2.2 Report Selection Criteria

To sort through the large amounts of data in the form of witness reports, we opted to first screen for quality and quantity of information content for each case. The primary databases were first screened for unresolved candidates 1) by using reports that had been previously curated: Project Blue Book (Sparks, 2020), UFOCAT2002 (CUFOS, 2022); 2) through hand-sorting: Project Blue Book, MUFON, GEIPAN; or 3) made easily accessible for semi-automatic sorting: NICAP. This subsample of unresolved UAP reports was then examined by hand with the goal of identifying sightings that were *least likely* to be the result of a witness failing to identify a known object. This was achieved by using four selection criteria:

1. *Reliability of observations.* Reports were included when there was more than one witness, when a single witness such as a military pilot or law enforcement officer had filed an official report, or there was corroborating physical evidence. We utilized only reports generated by at least one such witness or corroborated by multiple witnesses.
2. *Nearness of object.* To be included, the object viewed in the report must have been at least 0.15 degrees in angular size to provide sufficient surface area to visually identify shape and structure. As a reference, the full moon is about 0.45 angular degrees (1620 arcseconds) in diameter, so the object's apparent size must be at least 1/3 the size of the full moon. This is significantly larger than the resolution of a typical human eye, at 50 arcsecs (Santini and Rucci, 2006; Westheimer, 1979).
3. *Sufficient lighting.* Reports were selected where the object was seen in the day or when there was sufficient ambient light to see details of the object at night. For example, when a witness indicated the object was illuminated or that there was sufficient ambient light from city lights to illuminate the object.
4. *Sufficient detailed information.* Reports must have contained enough information to extract a majority of the physical characteristics of interest, as listed below.

The UAP reports were reviewed by Robert Powell, Larry Hancock, and Steve Purcell according to these criteria and agreed upon for inclusion based on the strength of each report.

An analysis using a similar approach and criteria was conducted for the U.S. Air Force (USAF, 1955) by Battelle (Zeidman, 1991) on approximately 4,000 Blue Book reports collected from 1947 through 1952, where 800 were rejected as being "extremely nebulous" and non-factual. Battelle's work resulted in the designation of either "not stated" or one of six shape categories:

elliptical, rocket and aircraft, meteor or comet, teardrop, lenticular or conical, and flame. Comparisons of the results from these different approaches are discussed in section 4.

2.3. Database Characteristics Selected

Once a UAP report was selected for inclusion in our study, the following physical, environmental, and contextual characteristics were captured from the report:

1. Shape
2. Estimated size
3. Kinematics (hover, speed, acceleration, odd motion)
4. Electromagnetic (EM) effects and EM emissions
5. Production of sound
6. Effects on the environment
7. Structure, color, luminosity, reflectivity
8. Date, time, duration of sighting
9. Nation, state, city, latitude, longitude
10. Closest distance between the witness and the UAP
11. Lowest altitude of the UAP
12. Number of UAP and if in a formation
13. Engagement by the UAP of any aircraft or witnesses

The analyses of shape, and its association to items 2-5 listed above, are presented in this paper. Effects on the environment, color, luminosity, spatiotemporal data, and other information were also extracted from the reports. However, these items (6-13 listed above) and their analysis will be presented in a subsequent paper.

2.4. Resultant Physical Characteristics Database

Starting with over 100,000 reports, our database filtering process yielded 301 reports that spanned a time frame of 69 years (1947-2016). The criteria described in section 2.2 eliminated 99.6% of the reports and left only those with high quality information in which we had confidence that the object remained unidentifiable.

Not every characteristic selected for the database was available in each UAP event. This was due to some characteristics not always being expressed, such as electromagnetic (EM) effects, or because the information was sometimes not available, such as the witness did not provide an estimated size of the UAP.

3 Analysis

3.1 Shape

Shape was chosen as an object's primary characteristic for comparison with other characteristics. Shape is a logical choice for sorting witness information. It is a characteristic that witnesses involuntarily key upon because it is an effective means of processing information in iconic memory (Reppa and Greville, 2020; Turvey and Kravetz, 1970).

The shape described by a witness can be affected by the aspect angle, the angle at which an object is viewed. The disk shape is a very good example of the significance of aspect angle in witness reports. Take a round coffee saucer and invert another saucer on top of it. If viewed from

the top or bottom, it will look circular or spherical. If seen from edge on, then it will appear more like a disk or an oval-shape. Furthermore, witnesses may choose a different description for the same object: disk or circle, triangle or delta, or cylinder or cigar.

Similar shapes can be described with slightly different terms. In the database analysis, these terms were combined into the shape categories presented in Table 2, where the resulting 17 basic categories of shapes are presented: disks (with and without domes), triangle, oval, sphere, cylinder, delta, cigar, light/plasma, lozenge/Tic-Tac, cone, rectangle/diamond, boomerang, egg, Saturn-like, shoe heel, circular, and miscellaneous. The “miscellaneous” category contains the following additional shapes, each with one or two occurrences: acorn, antique bathtub, barbell, bullet, changing shape, cube, flattened sphere, football, meteor-like light, oblong, round, tear shape, unknown, white light, z-shape propeller.

The most dominant shape reported was the disk, found in 110 of the 301 reports and making up 36.5% of the total number of reports. It is possible that the true number of disks seen is larger, as an oval could be considered a disk, as could a cigar shape, which could be a disk that is seen edge on. The second most frequent shape after the disk was the triangle, found in 33 reports and making up 11.0% of the total.

The average and median reported sizes of the most common shapes are also shown in Table 2. Size estimates are always problematic when viewing an object at a distance without any a priori information on its expected size. This study has tried to minimize that issue, as noted in section 2.2, by requiring an object to be at least 0.15 angular degrees in size and by screening for reliability of the observations. The sizes displayed in Table 2 are based on either the witness’s estimate of size and/or an estimate based on the object’s angular size and distance, where distance was either estimated by the witness or reconstructed based on the context of the sighting, e.g., “at the tree line.”

Witnesses reported size units in feet, and we leave that unconverted to meters to avoid giving a false sense of significant digits and thus precision.

Table 2
301 Selected Witness Reports: Shape and Size Summary

Shape	Reports #	Reports (%)	# Reports with size	Average size ^a (ft)	Median size (ft)
<i>Totals</i>	301	100	196	-	-
<i>Disk</i>	(110)	(36.5)	(89)	-	-
Disk with dome	16	5.3	11	75	30
Disk without dome	94	31.2	78	85 ^b	40
Triangle	33	11.0	29	163	170
Oval	26	8.6	22	47	30
Sphere	18	6.0	10	38	20

Cylinder	17	5.6	14	78	50
Delta	16	5.3	13	100 ^c	40
Cigar	10	3.3	8	172	150
Light/Plasma	9	3.0			
Lozenge/Tic-Tac	8	2.7	5	35	35
Cone	6	2.0	6	46	50
Rectangle/Diamond	6	2.0	5	263	300
Boomerang	5	1.8	4	300	300
Egg	5	1.8			
Saturn-like	4	1.3			
Shoe heel	4	1.3			
Circular	3	1.0			
Miscellaneous	21	7.0			

Table 2. UAP shape distribution and approximate sizes from our dataset. Shapes reported fewer than five times, or shapes with one or zero size estimates, are shaded grey and not included in the summaries of characteristics reported in the text. ^a Average size was calculated after dropping the high and low values from the sample. ^b There were several reports of a large disk without domes (300-1000 feet) that drove up the average value. ^c Delta shapes had a bimodal distribution with one grouping from 200-400 feet and the other between 20-50 feet. Italicized entries are totals or subtotals.

The number of reports of size (196) is smaller than the total number of reports (301) because not every witness was able to estimate a size and therefore not all shapes were assigned sizes.

The one shape that is consistently smaller when reported is the sphere, with a median size of 20 feet. The two largest shapes, based on median size reported, are the boomerang and rectangle/diamond shapes, each 300 feet.

3.2 Shape Reconstruction

Two of the basic shapes, disks and triangles, had at least ten detailed and consistent reports which we used to render drawings to represent these shape classes.

Disks: There were two dominant types of disk shapes: 1) a circular disk with a dome on its top (20-40 ft in diameter); and 2) a circular disk without a dome that came in two size categories: 2a) more elongated than the disk with a dome and 100-150 ft in diameter, and 2b) similar aspect ratio to the disk with a dome and 30-60 ft diameter. The diameter of such disks was the most common shape value extracted from reports. Estimates of the disk height were not often reported, although height was derivable in several reports where a diameter and ratio of diameter-to-height was provided.

- 1) **Disk with dome:** There were 11 reports of a disk with a dome that included size estimates. Nine of those reports provided a diameter-to-height ratio. Six of those nine indicated a 2.5:1 or a 3.0:1 ratio (Fig. 1). This type of disk was usually smaller than domeless disks, and appears circular when seen from its top or bottom.

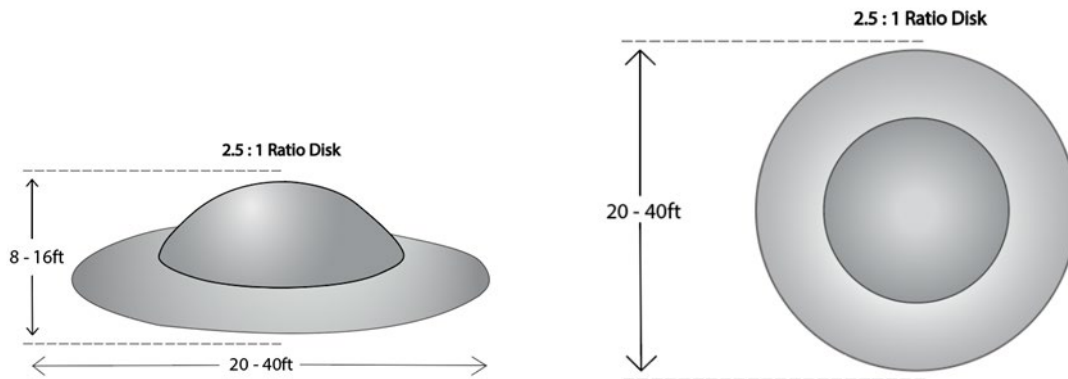

Figure 1. UAP rendering of 20-40 ft diameter disk with dome using consistent details from ten reports.

- 2) **Disk without dome:** Whenever a view from beneath was drawn, these disks were also circular in shape, but they lacked a dome. There were 78 reports of a disk without a dome that included size estimates. Of those, 20 provided information allowing their diameter-to-height ratios to be estimated. These domeless disk shapes fell into two distinct subcategories based on size and the ratio of their diameter-to-height (aspect ratio): elongated and shortened.

- a) **Elongated:** Eight of the 20 reports described large sizes and elongated aspect ratios between 5:1 to 10:1 (Fig. 2).

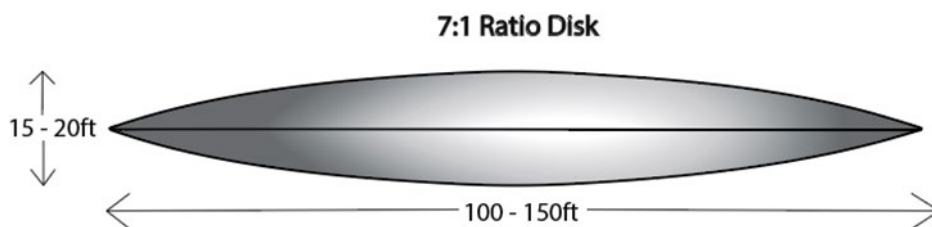

Figure 2. UAP rendering of elongated 100-150 ft diameter disk without dome using consistent details from eight reports.

- b) **Shortened:** Twelve of the 20 reports had smaller sizes and aspect ratios between 2.5:1 and 4.0:1 (Fig. 3)

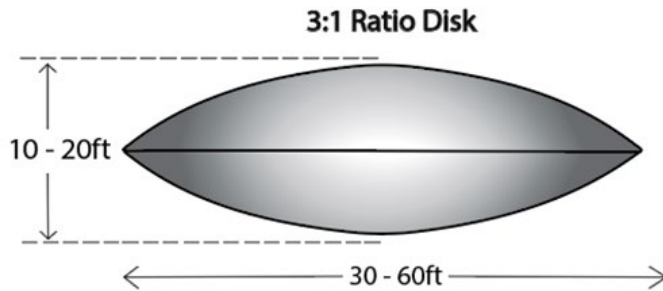

Figure 3. UAP rendering of 30-60 ft diameter shortened disk without dome using consistent details from twelve reports.

Triangles: The other dominant shape among the witness reports was the triangle, which made up 33 of the 301 reports. Of these 33, 29 had size estimates and 22 indicated whether the triangle was an isosceles (10) or equilateral triangle (12). Of the 10 isosceles triangles, eight reported size and, of those eight, four reported both the base and sides. Of the 12 equilateral triangles, all reported size. These two types of triangles were different from each other in terms of size and the configuration of lights on their surface.

- 1) **Isosceles triangle:** The 10 reports of UAP shaped like isosceles triangles were more varied in their description than reports for the equilateral triangles. The ratio of length-to-base was consistent at 2:1 across the four isosceles triangle reports. The size of these triangles varied in length from 30 ft to 300 ft. Only four isosceles triangle reports provided size for both the base and sides. Three reports of different sightings described multiple lights on the surface, but the described lighting patterns were not the same. Figure 4 shows the ratio configuration of the isosceles shaped UAP, but the overall sizes were highly variable.

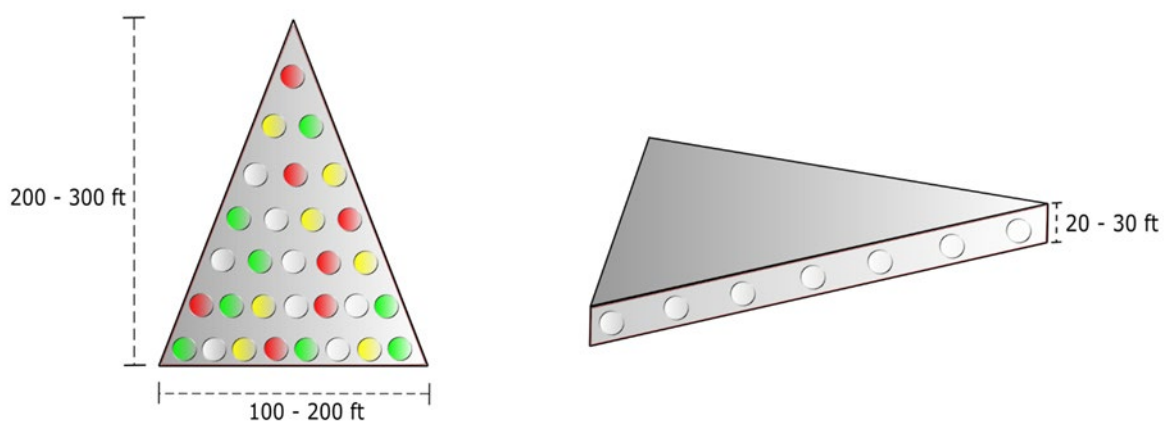

Figure 4. UAP rendering of triangle with isosceles shape with consistent 2:1 length-to-base ratios (from four reports); lengths varied from 30 ft to 300 ft (from ten reports).

- 2) **Equilateral triangle:** Of all the UAP reports where shapes were described, the 12 reports of equilateral triangles were the most consistent in size, shape, and lighting. Ten of 12

reports described a light on each vertex of the triangle. The color of the lights was always either all red, all white, or red and white. Six of the 12 reports described a smaller red light at the centroid of the triangle. All 12 of the reports estimated size, and 10 of the 12 reports estimated the sides of the triangle at 100 ft or larger. The most consistent description in these 12 reports of UAPs shaped as equilateral triangles is the one depicted in Figure 5.

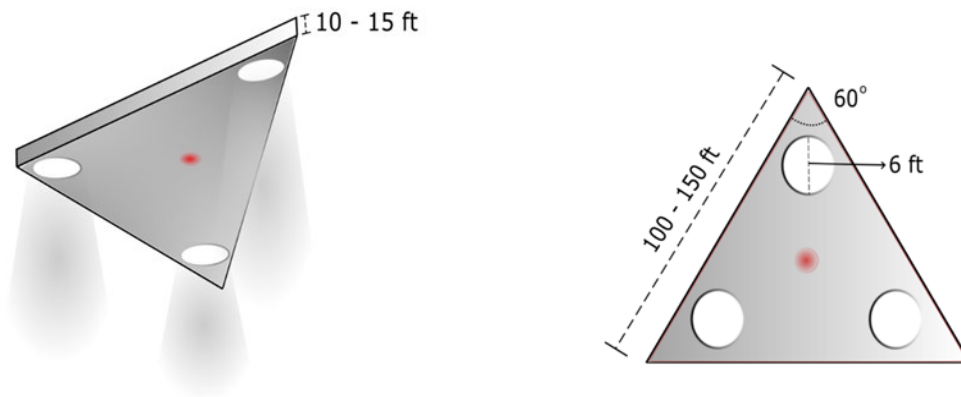

Figure 5. UAP rendering of 100-150 ft triangle (from 10 reports) with equilateral shape (from 12 reports).

3.3 Kinematics, Sound, and EM Characteristics as a Function of Shape

We explore the question of whether the potentially propulsion-related characteristics of kinematics (speed, acceleration, style of motion), presence of sound, and electromagnetic (EM) effects can be categorized by shape.

For known aerial objects, shape, kinematics, and presence of sound are often closely related to the propulsion mechanisms used to keep the objects aloft. For instance, helicopters hover by generating lift using rotating blades, and these blades produce distinctive harmonics and acoustic doppler signals (Eibl et al., 2017). Known objects hovering without producing sound would typically be either neutrally buoyant (e.g., a round hot air balloon in no wind) or subject to specific up-drafting conditions (e.g., an aerodynamically winged hawk).

For known vehicles, EM fields are typically generated by alternators, cables, and electric motors, but these fields are small, e.g., $3.5 \mu\text{T}$ and 3 V m^{-1} (Tell et al., 2017) and have detectable effects only within tens of meters of the source. Reports of UAPs affecting EM-sensitive electronic components of cars, planes, and personal gear (CUFOS, 1981) beyond what would be expected for commercially made devices (e.g., cars, planes) have given rise to hypotheses about UAP emitting strong EM fields, perhaps due to novel EM propulsion mechanisms (e.g., Holt, 1979). Military and civilian pilots have also described unexpected EM interference in UAP reports (Haines, 1992; Weinstein, 2012).

An object's capabilities are not limited to what is or isn't reported. All that can be concluded from the UAP reports is that an object has at least the characteristics as witnessed and reported.

Table 3 displays the characteristics potentially related to propulsion associated with each shape whenever there were two or more reports of a given characteristic type for that shape.

Table 3
 301 Select Witness Reports: Shape and Potentially Propulsion-Related Characteristics^a

Shape	Reports		Reports with size	Ave size ^b (ft)	Mdn size (ft)	Hover	Max speed range ^c mph	Extrm. accel.	Odd motion	Reported on sound	Hover & mil. speed (& no sound #ab, #nr) ^d	EM
	#	%										
Total Counts #	301	100	202			139	slow 0 prop 4 civilian 6 military 18 missile 5 extreme 10	40	wobble 19 spin 13	absent 47 present 38	33 (16, 14)	44
All disks	110	36.5	89	-	-	53		13	wobble 13 spin 6	absence 16 present 12	12 (5,6)	18
Disk w/out dome	94	31.2	78	85 ^e	40	42	extreme 5	11	wobble 11 spin 5	absence 14 other 9	9 (4,5)	17
Disk with dome	16	5.3	11	75	30	11	military 4	2	wobble 2 spin 1	absence 2 hum 3	3 (1,1)	1
Triangle	33	11.0	29	163	170	32	extreme 3	8	spin 2	absence 15 soft 5	11 (8,3)	0
Oval	26	8.6	22	47	30	12	missile 3	4	wobble 3 spin 2	absence 4 loud noise 7 low whirr 1	1 (1,0)	7
Sphere	18	6.0	10	38	20	8	extreme 2	4	spin 1	absence 2 other 1	5 (1,3)	3
Cylinder	17	5.6	14	78	50	6	military 3	0	0	absence 1 other 4	0	1
Delta	16	5.3	13	100 ^f	40	3	military 2	0	wobble 1	absence 3 other 1	0	3
Cigar	10	3.3	8	172	150	7	military 4	4	spin 1	absence 1 hum 2	2 (0,1)	3
Amorphous (Light or Plasma)	9	3.0	-	-	-	0	military 5	3	0	nr	0	1
Lozenge (tic-tac)	8	2.7	5	35	35	2	missile 2	2	wobble 1	nr	1 (0,1)	1
Cone	6	2.0	6	46	50	5	civilian 2	0	spin 1	absence 1 other 2	0	3

Rectangle Diamond	6	2.0	5	263	300	6	prop 4	0	wobble 1	absence 1 whine 1 rumble 1	0	0
Boomerang	5	1.8	4	300	300	4	civilian 2	2	0	absence 3 low buzz 1	1 (1,0)	2
Egg	5	1.8	1	n/a	n/a	1	civilian 2	0	0	nr	0	2
Saturn-like	4	1.3										
Shoe heel	4	1.3										
Circular	3	1.0										
Misc.	21	7.0										

Table 3. UAP shape distribution, approximate sizes, and propulsion-related characteristics from our database of 301 selected reports. ^a Shapes reported fewer than five times are not included in the summaries of characteristics reported in the text and are shaded grey. ^b Average size was calculated after dropping the high and low values from the sample. ^c Maximum speed ranges, in mph: hover 0 - 10; slow 10 - 100; propeller 100 - 300; civilian 300 - 750; military 750-2000; missile 2000-4000; extreme > 4000. ^d ab = absence of or faint sound reported; nr = witness did not report on sound. ^e There were several reports of large disks (300-1000) feet in size that drove up the average value. ^f Bimodal distribution with one grouping from 200-400 feet and the other between 20-50 feet. *Italicized* entries are totals or subtotals. **Bold** entries are shapes with five or more corresponding reports.

Kinematics: Table 3 shows the number of times for each shape that the following kinematic conditions were reported: hovering, maximum speed, extreme acceleration, odd motion, and an unusual kinematic range (combination of hovering and high speed).

- **Hovering:** Hovering is a speed category that, conventionally, requires airflow (for aerodynamic lift (e.g., conventional aircraft and helicopters), buoyancy (e.g., balloons and blimps), or thrust (Harrier or F-35 jets). It is not unusual by itself, but might be if coupled with other characteristics, such as the presence of no sound, remaining stationary against a strong wind without wings or lift surfaces, or abrupt transitions between high speed and hovering. Craft that rely on buoyancy, such as blimps, with speeds up to ~70 miles per hour (Goodyear, 2023), cannot easily remain stationary in winds aloft. Average jet stream windspeeds are about 90 miles per hour, and the maximum recorded windspeed is almost 260 miles per hour (NOVA, 2023; NOAA, 2023). For the purposes of this paper, any estimated object speed <10 miles per hour was defined as hovering.
 - In the 301 UAP reports reviewed, the ability to hover was reported at least twice as a characteristic of every shape except for the light/plasma-type UAP and the egg-shaped UAP. Triangles were most consistently reported to hover, at 32 out of 33 reports. Other shapes consistently reported as hovering were the rectangle/diamond (6 out of 6) and cone (5 out of 6).
- **Maximum speed:** Speeds were estimated in miles-per-hour and placed in the following ranges: slow (10-100 mph); propeller aircraft and helicopters (100-300 mph); civilian jet aircraft (300-750 mph); military jet aircraft (750-2000 mph); missile (2000-4000 mph); and extreme (> 4000 mph). At least two instances of exceeding a speed range in each shape category were required for the selected maximum speed category to be noted in Table 3.

- All shapes were reported to have moved at speeds beyond that of civilian jet aircraft, except for cone, rectangle/diamond, boomerang, and egg.
- **Extreme acceleration:** Extreme acceleration was defined as any moving object that was described as making a sudden right angle or 180° turn or an object that appeared to accelerate from a much slower velocity and disappeared from sight within one to two seconds. Depending on the witness's eyesight, sky conditions, and the object's angular size and distance to the horizon, this rate of disappearance equates to acceleration values in hundreds to thousands of g-forces (Knuth et al., 2019).
 - Extreme acceleration was reported at least twice in nine shapes: disk with dome (11), disk without dome (2), triangle (8), oval (4), sphere (4), cigar (4), light/plasma (3), lozenge (2), and boomerang (2).
 - Note that one of the lozenges counted in this category is the tic-tac lozenge described by Commander David Fravor during his highly publicized encounter in November 2004 (Knuth et al., 2019).
- **Odd motion:** Odd motion is characterized by descriptions of spinning or wobbling motions.
 - Odd motions, including the “falling leaf” (similar to a leaf’s rhythmic swaying as it floats to the ground), were noted in a total of 32 of the 301 reports. A wobbling motion was most commonly reported in disks (13) and oval (3) shapes, and spinning was also most commonly reported in disks (6) and oval (2) shapes. There were two reports of spinning triangles.
- **Unusual kinematic range:** Unusual kinematic range is described by the ability to both hover and travel at military speeds of above 750 mph (>Mach 1).
 - Very few known craft have both the ability to hover and travel at high speed, and the ones that do will generate considerable noise while hovering. Balloons use buoyancy to remain afloat and their maximum groundspeed will be related to winds aloft (<300 mph); gliders use gravity and air currents to move and hover; and powered aircraft use rapid air movement generated either by noisy mechanical blades or loud thrusters to hover. There are 33 instances noted in Table 3 where a UAP was seen hovering as well as traveling at estimated speeds of greater than 750 miles per hour. (Above 5,000 feet, this is faster than Mach 1.) The combination of these two attributes in one report was most often seen for triangular objects; 11 reports (33% of triangle reports) indicated both high speed and hovering.

Sound: Sound or the lack of sound were noted whenever it was determined that a witness would have reasonably been able to discern if sound was evident. In the context of UAP, Mead et al. (2023) examined how sound is attenuated in air primarily through spherical spreading (frequency independent) and absorption (higher absorption at higher frequencies). They showed that a 500 Hz signal with a source level of 140 dB (equivalent to a jet aircraft at 50 m) will become discernable above the ambient noise floor (26 dB) in a rural environment at a distance of approximately 14 km. In our cases, if the witness was a pilot in an aircraft or a driver of an auto on a highway, then any mention of a lack of sound could be reasonably attributed to a high ambient noise floor, and we did not count it as a definitive “absence of sound.”

A wide variety of sounds were reported: faint whir, flutter, helicopter, high pitch, humming, loud noise, low buzz, low frequency purr, low whir, no sound, pulsating, sound, vibration, whir, whistle, and whoosh. Due to the wide variety and lack of quantitative value in these sound words, we grouped sound types, when necessary, into five categories: sound not reported (nr), absence of sound (ab), loud sound, soft sound, and other sound. See Table 3.

- Valid mention of sound or lack of sound was noted in 85 reports. The most common report on sound was the lack of sound at close range. This was the case in 47 of the 85 reports on sound. The lack of sound often evoked an extreme surprise from a witness. The triangle was the object consistently reported as the quietest, with all 20 of its reports on sound noting absence or soft sound (Table 3; Marler, 2013). The oval was the object consistently reported as the loudest, with seven reports noting a loud noise, one a low whirr, and four an absence of sound.
- Either the absence of sound (ab) or sound not reported (nr), *coupled with* unusual kinematic range, was found in 33 reports. Sixteen of these reports specifically mentioned an absence of sound: disk without dome (4), disk with dome (1), triangle (8), oval (1), sphere (1), and boomerang (1).

EM: Electromagnetic effects were defined as whenever witnesses associated the UAP with EM interference, such as loss of radio reception, cell phone interference, battery failure, automobile failure, etc.

- EM interference was reported in two or more cases for the disk without dome (17), oval (7), sphere (3), delta (3), cigar (3), cone (3), and boomerang (2). Notably, EM interference was never reported with any triangle shaped UAP even though this shape had the second largest number of reports (33).

4 Discussion

4.1 Comparison to previous studies.

It is difficult to draw conclusions from comparisons to the many studies where the data were not filtered or, if selections were made, the methods were not described. In those instances, the percentages of each shape (e.g., Table 1) are also skewed by the inclusion of cases that are hoaxes, likely identified, of objects of small angular size (less than 0.15 degrees), or contain insufficient information.

Only one of the studies listed in Table 1 describes their report selection process, the Battelle report. In 1949, the Air Force's internal Project SIGN (Truettner and Deyarmond, 1949) concluded that there were four basic shapes of UFOs: disk, cigar, sphere, and balls of light. However, in 1955, the U.S. Air Force commissioned the Battelle Institute to conduct the first outside analysis of UFO shapes and characteristics. This analysis was done using the Air Force's Project Blue Book files, where a net of 3,200 filtered reports from 1947 to 1952 were used to create Special Report 14 (US Air Force, 1955).

This Battelle report contained the first analysis that included screening the reports and categorizing them as likely valid or invalid. Their screening was done by manually reading reports and the first step "...was the deduction of discrete facts from subjective data... In those cases in which an attempt to reduce the information to a factual level failed completely, the

report was eliminated from further consideration...” (US Air Force, 1955). This removed 800 reports from an initial 4,000. They next marked reports that had contradictory statements or very nebulous descriptions; and then they attempted to identify the object sighted. As such, their selection process was significantly different from ours, making direct comparison of shape percentages difficult.

The Battelle Institute’s Special Report 14 (USAF, 1955) only encompasses UFO reports from 1947 to 1952 and features a category of 434 reports classified as “unknown.” Of this set, the most frequent shape category was elliptical, which comprised 44.9% of their reports. This percentage is similar to the disk and oval shapes of this paper, which together made up 45.2% of our reports (Table 2). A drawing that was made in the Battelle report (Fig. 6) has a similar shape and diameter-to-height ratio as our domed disk (Fig. 1). However, Battelle did not remove reports of objects of small angular size, so the comparison of shape percentages is not straightforward.

One notable difference between the Battelle report and ours is that the number of triangular shaped objects in the Battelle report were too few to have created their own category; whereas in our analysis, triangles (33 reports) along with delta shapes (16 reports) make up 16.3% of our 301 reports (Table 2). A review of the dates of our reports shows the triangular shape not appearing until the 1970s. Since the Battelle report was completed in 1955, this may explain this difference.

Our other shape categories percentages do not align with Battelle’s because their remaining unknowns (after elliptical) were divided into very different shape categories: rocket/aircraft, meteor, lenticular/cone/teardrop, flame, other, and not stated.

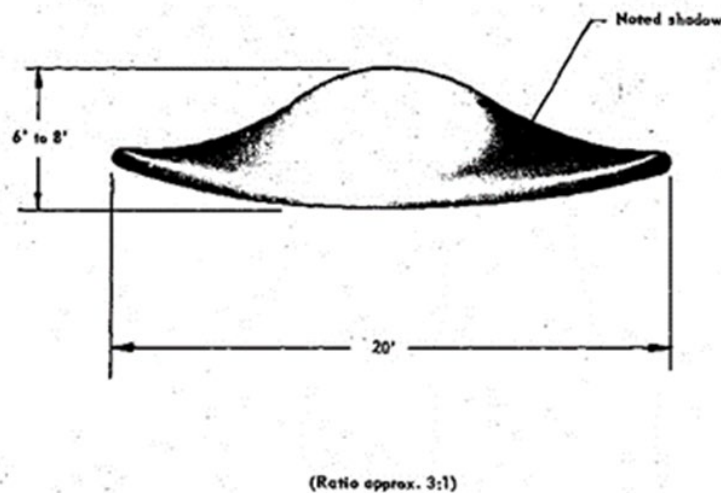

Figure 6. Drawing of UAP disk shaped object that appeared in the Battelle Report (US Air Force, 1955).

Studies that did not filter the database have even more tenuous shape category comparisons with ours.

Star-like objects and “lights in the sky” don’t exist in our dataset (Table 2) because they don’t meet our criteria for the minimum angular size of the object needed to determine shape. In the analyses of their unfiltered databases, lights or star-like objects made up 21% (Gindilis, 1979), 13% (Teodorani, 2009), 50% (Dittman, 2014), and 16% (AARO, 2023). Including star-like objects in their total number of reports makes direct comparison of specific shape percentages impossible between studies.

Reports of disk shapes (110) and oval shapes (26) make up 45% of our filtered cases, but considerably fewer in five unfiltered studies: 15% (Gindilis, 1979); 2% (UKMoD, 2000); 7% (Teodorani, 2009); 10% (Dittman, 2014); and 2% (AARO, 2013). This difference may be due, in part, to the fact that we eliminated objects whose angular size was smaller than 0.15 deg, while these studies included objects in angular size down to star-like points of light.

Conversely, Johnson and Saunders (2002) have considerably more disk and oval reports than ours. Their study indicates that 62% of the reports in their database include the shape word “disk” or “domed disk” (56% and 6% respectively). Separate categories not included in this tally are oval (2%), ovoid (2%), ellipse (1%), ball (5%), circle (<1%). Their database contains in excess of 120,000 reports but they used only about 8,000 reports to generate their breakdown of shapes and they did not indicate the criteria they used that resulted in only a small portion of their database being used.

Triangle and delta shapes make up 16.3% of our 301 reports, but triangles and delta shapes were variously “not reported” (Gindilis, 1979), 7% (UKMoD, 2000), 8% (Teodorani, 2009), and 10% (Dittman, 2014), which reflects suggestions that reports of this shape may have come into prominence in the 1970s.

Variation in the types of shapes beyond the more common ones just discussed is a confounding factor in all of the studies. Some of the shapes listed in Table 2, such as diamond, circular, boomerang, or egg, could be ascribed to variations in how witnesses described an object or the angle at which the object was viewed. But the cone, shoe heel, and Saturn-like shapes, each making up 1%-2% of the reports, are very distinct descriptions that would be difficult to construe as a different view of the more commonly described object shapes; as are the singular sighting reports of shapes described as barbell, acorn, and upside-down antique bathtub. One could argue that a report of an uncommon shape either increases or decreases judgements of witness reliability. On the one hand, uncommon shapes might indicate errors on the part of the witnesses, while on the other, it might indicate that the witnesses are unbiased by media reports of object shapes seen by others.

4.2 Application to Future Work

Report analyses. More work needs to be done in the analysis of UAP shapes and other characteristics from historical and ongoing UAP reports. Going forward, this can be done by improving the manner in which shapes are identified by introducing a standardized technique with drawings that a witness can compare against their memory. A better analysis of UAP characteristics from older databases could be enhanced using Natural Language Processing (NLP). This would allow for an automated filtering of a database and NLP could also better categorize shapes through the evaluation of text usage. Comparing the results of NLP report analyses with historical human report analyses would usefully inform future work in this area.

Machine learning algorithms or artificial intelligence could also be utilized to search for commonalities in UAP characteristics that might not otherwise be noticed.

The relationship between shape and speed (Table 3) may be useful in evaluating possible propulsion mechanisms that would explain certain UAP reports. Nine of the shapes listed in Table 3 had been seen hovering and moving at very high speeds (750 mph or greater): disk with and without dome, triangle, oval, sphere, cigar, light/plasma, lozenge, and boomerang. The triangle had the most instances where the witnesses saw it both hover and move at high speeds (11 out of 33 reports). Very few aircraft can both hover and move at high speeds. A helicopter can hover but not move at high speeds; jets can move at high speeds but not hover. There is an exception to the latter with the Harrier jets and the modern F-35 jets that can hover by controlling their exhaust direction. However, both of those aircraft are big enough that they would be easy to identify at a distance that meets the > 0.15 degrees of angular size, and they would normally produce considerable sound. Our select database contained 30 reports of objects that could hover, move at greater than Mach 1, and where either no sound or an absence of sound was reported.

Application to satellite images. Optical satellites that use push broom scanning techniques can detect large, non-stationary objects (Keto & Watters, 2023). Image processing detection algorithms for data collected by these satellites could be designed to include as targets the larger reported UAP shapes (100 - 300 feet) such as triangle, disk-without-dome, cigar, rectangle/diamond, and boomerang.

Synthetic aperture radar (SAR) satellites (Guo, 2019) may also prove useful for UAP detection, imaging, and morphological characterization, as well as measuring distance, speed, radar absorption and reflection. The older, lower resolution SAR satellites like SEASAT or ERSAT might be used for finding, detecting, and imaging large, stationary UAP, e.g., momentarily hovering objects like triangles, domeless or domed disks, cigars, boomerangs, and rectangles/diamonds. Smaller sized objects, on the other hand, would best be detected and imaged by the newer, finer resolution SAR satellites with resolutions in the one-meter range.

If we are limited to using already processed digital SAR imagery, that will mean seeing only UAP which are stationary and very near or on the ground.

If there is access to the raw SAR data along with information sufficient to reconstruct the motion between the satellite and the UAP, this would enable us to reprocess and refocus the data to meet the particular kinematic needs of imaging a moving UAP in the air.

5 Conclusion

This paper provides robust information on basic UAP shapes and associated sizes, kinematic and electromagnetic effects, and presence of sound, collected from 301 UAP reports submitted between 1947 and 2016. The analysis draws on raw UAP report data from five primary databases, one military and four civilian. Our approach minimizes the uncertainty in these witness reports by selecting for reliability of observations, object angular size greater than 0.15 degrees, sufficient lighting, and sufficient information detail. The authors are unaware of any previous study that attempted to filter UAP reports using criteria similar to these. In most cases, existing databases do not consider angular size or lighting or, if they have, the criteria for the

filtering have not been shared. Thus, one benefit of our analysis is its basis in the most reliable UAP reports available for the time period studied.

The UAP shape most frequently reported in our analysis is the disk. There are three basic versions of the disk shape: a domed disk about 30 feet in diameter with an aspect ratio of 2.5 to 1; a domeless version approximately 45 feet in diameter with aspect ratio of 3 to 1; and a larger and elongated domeless version about 125 feet in diameter with an aspect ratio of about 7:1.

The second most common shape described in our analysis is the triangle shape, which appears in our dataset to have come into prominence since the 1970s. The two most common triangle configurations are isosceles and equilateral. The UAP with the equilateral shape is almost always configured with large circular lights at each apex of the triangle's underside and a smaller light in the bottom center of the triangle

UAP shapes exhibited some distinct size differences. The rectangle/diamond and boomerang were the largest shapes reported (300 feet), but there were few instances (6 and 5 respectively) of these very large sizes in our database. The triangle shape, with 33 reports, was also reported as large. Its average and median values were consistent at 163 feet and 170 feet respectively. The cigar shaped UAP had an average of 172 feet and a median of 150 feet. The smallest UAP was the sphere with an average size of 38 feet and a median size of 20 feet. The lozenge had both an average and median of 35 feet in length (the tic-tac lozenge described by Commander David Fravor was estimated to be 56 ft; Knuth et al., 2019).

Hovering was reported for all of the UAP shapes in this study except light/plasma. The triangle shape almost always displays hovering capability, with 32 of 33 reports noting this characteristic.

UAP with the ability to achieve high speeds of Mach 1 or greater (33) or extreme acceleration (40) were reported. The triangle, sphere, cigar, and the light/plasma shapes were most likely to display extreme acceleration. The only UAP shapes that were never reported to demonstrate high speeds or acceleration were the cone, rectangle/diamond, egg, and boomerang shapes.

The most common sound reported for UAP was "no sound at all" (47). A large variety of tonal words (whirr, hum, etc.) were used to describe sounds ranging from faint to loud.

EM interference with nearby electronics is a feature in 44 of the reports, although it never constitutes more than half the sightings for any particular shape. It is noteworthy that EM interference was never reported related to a triangle.

The combination of unusual kinematic range and absence of sound was found in 16 reports which specifically mentioned objects that could hover, travelled faster than Mach 1, and exhibited an absence of sound: disk without dome (4), disk with dome (1), triangle (8), oval (1), sphere (1), and boomerang (1).

This report's classification of UAP shape and related characteristics from historical data that have been filtered for reliability will help inform the design of theory, experiments, and instrumentation to advance our understanding of the nature, causes, and consequences of UAP.

Data Availability Statement

All 301 files used in the development of this paper are available at <https://doi.org/10.5281/zenodo.10287332>

Raw source databases can be accessed here:

1. Project Blue Book (1947-1969) at fold3.com
2. NICAP (1956-present) at nicap.org
6. CUFOS (1967-2002) as UFOCAT2002 at cufos.org (fee)
3. MUFON paper files (1970-1999) and electronic files (2000-present) at mufon.com (fee)
4. GEIPAN at geipan.fr

Acknowledgements

The authors wish to thank Ike Okafor of the University of Toronto, and the Senior Officer of the Office of Access and Outreach, for financially supporting Laiba Hasan, Robinson Truong, and Tobi Kamoru with stipends for their work in the project and for developing a working relation between the Scientific Coalition of UAP Studies and the University of Toronto; Steve Purcell for his support in evaluation of cases for the final 301 case database; and Alan DiCenzo for contributions to the information regarding synthetic aperture radar.

Authors' Roles:

R. Powell: Conceptualization, writing--original draft preparation, data curation, project administration, formal analysis. S. Little: Writing--review, and editing, formal analysis. L. Hancock: Data curation. L. Hasan: Visualization: created the drawings. R. Truong: Formal analysis. T. Kamoru: Formal analysis. I. Okafor: Funding acquisition and supervision of the students.

Funding: Except for the students' stipends, no funds were received for this work.

The authors report no conflict of interest. S. Little and R. Powell are affiliates of the Galileo Project associated with Harvard University.

References

- AARO (2023). AARO UAP Reporting Trends, 1996-2023. Cleared for open publication April 17, 2023. *U.S. All-domain Anomaly Resolution Office*. Accessed September 25, 2023 https://www.aaro.mil/Portals/136/PDFs/Latest_UAP_Reporting_Trends_Presentation.pdf
- Aldrich, J. (1997). Top-Secret 1949 Document, Project 1947. *J. Allen Hynek Center for UFO Studies*. Retrieved March 19, 2023, from http://www.cufos.org/PDFs/pdfs/IUR_article1.pdf
- Ballester-Olmos, Vicente-Juan (1976a). Are UFO Sightings Related to Population?, In *Proceedings of the 1976 CUFOS Conference*, Nancy Dornbos (editor), Center for UFO Studies, Northfield (pp. 15-24). Retrieved March 19, 2023, from http://www.cufos.org/PDFs/books/Proceedings_of_the_1976_CUFOS_Conference.pdf
- Ballester-Olmos, Vicente-Juan (1976b) Catalog of 200 Type-I UFO Events in Spain and Portugal, *Center for UFO Studies, Evanston, IL*. Retrieved March 19, 2023, from http://www.cufos.org/PDFs/books/Catalogue_of_200_Type_I_UFO_Events_in_Spain_and_Portugal.pdf

- Brazil, Government of, (2022, May 20). *Official UFO Night in Brazil*. [Serviços e Informações do Brasil](https://www.gov.br/en/government-of-brazil/latest-news/2022/official-ufo-night-in-brazil). Retrieved January 15, 2023, from <https://www.gov.br/en/government-of-brazil/latest-news/2022/official-ufo-night-in-brazil>
- Central Intelligence Agency. (1953). *Report of Meetings of Scientific Advisory Panel on Unidentified Flying Objects Convened by Office of Scientific Intelligence, CIA, January 14-18, 1953*. Page 201. Retrieved January 15, 2023, from <https://history.nasa.gov/SP-4407/ETUv1.pdf>
- CUFOS. (2002). J. Allen Hynek Center for UFO Studies (CUFOS) UFOCAT2002 database. <http://www.cufos.org/ufocat.html>. Now UFOCAT-2023 <https://cufos.org/cufos-publications-databases/ufocat/>
- CUFOS. (2020), J. Allen Hynek Center for UFO Studies board, <https://cufos.org/about-us/cufos-board-consultants-and-friends/>
- Clark, Jerome (1998), *UFO Encyclopedia: The Phenomenon from the Beginning, 2nd edition*. Omnigraphics. ISBN-13: 978-0780800977
- Dittmann, G. and Rutkowski, C. (2014). *UFOs Over Canada: 25 Years of UFO Reports*. Ufology Research, Winnipeg Canada. <http://www.canadianuforeport.com/survey/UFOsOverCanada.pdf>
- Eibl, E. P., Lokmer, I., Bean, C. J., & Akerlie, E. (2017). Helicopter location and tracking using seismometer recordings. *Geophysical Journal International*, 209(2), 901-908
- ESD. (2023). *UFO Fact Sheet*. Executive Services Directorate, United States Government. Retrieved March 19, 2023 from https://www.esd.whs.mil/Portals/54/Documents/FOID/Reading%20Room/UFOsandUAPs/2d_af_1.pdf
- GEIPAN (Group for Study and Information on Unidentified Aerospace Phenomena). (2023, January 15). *The GEIPAN Mission*. GEIPAN. Retrieved January 15, 2023, from <https://geipan.fr/en/node/58792>
- Gindilis, L. M., Men'kov, D. A., & Petrovskaya, I. G. (1979). *Observations of Anomalous Atmospheric Phenomena in the USSR: Statistical Analysis; Results of Processing First Sample of Observational Data*. Translated in *NASA Technical Memorandum No. 75665, 1980*. Center for UFO Studies, original copy available from CUFOS http://www.cufos.org/PDFs/pdfs/Phenomena_in_USSR_A-548.pdf
- Goodyear. (2023, March 19). *Blimp Science*. Goodyear. Retrieved March 19, 2023. <https://gyblimpeast.azurewebsites.net/behind-the-scenes/blimp-science.html>
- Q. Guo, H. Wang and F. Xu. (2019). Aircraft Detection in High-Resolution SAR Images Using Scattering Feature Information," *2019 6th Asia-Pacific Conference on Synthetic Aperture Radar (APSAR)*, Xiamen, China, 2019, pp. 1-5, <https://doi.org/10.1109/APSAR46974.2019.9048502>
- Hall, Richard. (1994). *The Quest for The Truth About UFOs: A Personal Perspective on The Role Of NICAP*. National Investigations Committee on Aerial Phenomena. Retrieved January 16, 2023 from <http://www.nicap.org/papers/hall-IUR1994.htm>
- Haines, R. F., (1992). Fifty-six aircraft pilot sightings involving electromagnetic effects. NICAP. <https://www.nicap.org/92apsiee.htm> accessed 2023/09/16
- Hayes, Matthew. (2020). Hayes, M. (2020). UFOs in Canada. In *The Canadian Encyclopedia*. Retrieved January 15, 2023 from <https://www.thecanadianencyclopedia.ca/en/article/ufos-in-canada>
- Hendry, Allan. (1979). *The UFO handbook: A Guide to Investigating, Evaluating, and Reporting UFO Sightings*, First Edition. Doubleday and Co. ISBN-13: 978-0385143486.

- Holt, A. 1979. Field resonance propulsion concept, NASA (HASA-TM-80961)
<https://ntrs.nasa.gov/api/citations/19800010907/downloads/19800010907.pdf> accessed 2023/09/20
- Johnson, Donald A., Saunders, David R., (2002) *The UFOCAT 2002 User's Guide*. Bow, New Hampshire: Sun River Research Institute. Retrieved March 19, 2023 from
<https://cufos.org/PDFs/pdfs/UFOCAT%20Codebook.pdf>
- Keto, E., & Watters, W. A. (2023). Detection of Moving Objects in Earth Observation Satellite Images. *Journal of Astronomical Instrumentation*, World Scientific
<https://doi.org/10.1142/S225117172340007X>
- Knuth K. H., Powell R. M., Reali A. P. A. (2019). Estimating Flight Characteristics of Anomalous Unidentified Aerial Vehicles in the 2004 Nimitz Encounter. *Proceedings*. 2019; 33(1):26. <https://doi.org/10.3390/proceedings2019033026>
- Marler, David (2013). *Triangular UFOs: An Estimate of the Situation*. Dolan, ISBN 978-1490465814
- Mead, A. et al., (2023). Multi-band acoustic monitoring of aerial signatures *Journal of Astronomical Instrumentation*. 12(1), 2340005.
<https://doi.org/10.1142/S2251171723400056>
- MUFON. (2023, March 19). *Mutual UFO Network*. Retrieved March 19, 2023 from
<https://mufon.com/>
- NARCAP. (2023, March 19). *What We Do*. National Aviation Reporting Center on Anomalous Phenomena. Retrieved February 11, 2023 from <https://www.narcap.org/what-we-do>
- NUFORC. (2023, March 19). National UFO Reporting Center. Retrieved January 16, 2023 from
<https://nuforc.org/about-us/>
- NZDF. (2010). *Unidentified flying objects (UFO) files: copies for release to the public*. New Zealand Defence Force. Retrieved January 15, 2023 from
<https://natlib.govt.nz/records/22979464>
- NICAP. (1964). The UFO Evidence, Section XII, Patterns In *The UFO Evidence*, National Investigations Committee on Aerial Phenomena, Washington, D.C. Retrieved March 19, 2023 from http://www.nicap.org/ufoe/section_12.htm
- NOAA. (2023, March 19). *Integrated Global Radiosonde Archive*. National Oceanographic and Aeronautical Administration, National Centers for Environmental Information.
<https://www.ncei.noaa.gov/products/weather-balloon/integrated-global-radiosonde-archive>
- NOVA, (2023, March 19). *Frequently Asked Questions about the Jet Stream*. Public Broadcasting System, NOVA Balloon Science.
<https://www.pbs.org/wgbh/nova/balloon/science/jetstream.html>, accessed March 12, 2023
- ODNI. (2021). *Preliminary Assessment: Unidentified Aerial Phenomena, June 25, 2021*. Office of the Director of National Intelligence. Retrieved September 16, 2022 from
<https://www.dni.gov/files/ODNI/documents/assessments/Preliminary-Assessment-UAP-20210625.pdf>
- ODNI. (2023). *2022 Annual Report on Unidentified Aerial Phenomena*. Office of the Director of National Intelligence. Published January 12, 2023. Retrieved September 25, 2023 from
<https://www.dni.gov/files/ODNI/documents/assessments/Unclassified-2022-Annual-Report-UAP.pdf>
- Reppa, I., Williams, K.E., Greville, W.J. et al. (2020). The relative contribution of shape and colour to object memory. *Memory and Cognition*, 48, pp 1504–1521.
<https://doi.org/10.3758/s13421-020-01058-w>

- Rodeghier, M., (1981) UFO reports involving vehicle interference: a catalogue and data analysis, *Center for UFO Studies*.
http://www.cufos.org/PDFs/books/UFO_REPORTS_INVOLVING_VEHICLE_INTERFERENCE.pdf
- Ruppelt, Edward J. (1956). *The Report on Unidentified Flying Objects*. Doubleday. ISBN-13: 9780598368362. <https://www.gutenberg.org/ebooks/17346>
- Santini, F., and M. Rucci. (2006). Depth perception in an anthropomorphic robot that replicates human eye movements. *Proceedings 2006 IEEE International Conference on Robotics and Automation, ICRA 2006.*, Orlando, FL, pp. 1293-1298, <https://doi.org/10.1109/ROBOT.2006.1641887>
- Sparks, Brad, (2020), *Comprehensive Catalog of 2,200 Project Blue Book UFO Unknowns: Database Catalog*, NICAP, http://www.nicap.org/bb/BB_Unknowns.pdf
- Swords, M., Powell, R., Thieme, R., Svahn, C., Chalker, B., Greenwood, B., et al. (2012). *UFOs and Government: A Historical Inquiry*. San Antonio, TX: Anomalist Books. ISBN-13: 978-1933665580
- Tell R. A., Robert Kavet, Electric and magnetic fields <100 khz in electric and gasoline-powered vehicles, *Radiation Protection Dosimetry*, Volume 172, Issue 4, 2 December 2016, Pages 541–546, <https://doi.org/10.1093/rpd/ncv533>
- Teodorani, Massimo. (2014). A Comparative Analytical and Observational Study of North American Databases on Unidentified Aerial Phenomena.
https://www.researchgate.net/publication/253464694_A_Comparative_Analytical_and_Observational_Study_of_North_American_Databases_on_Unidentified_Aerial_Phenomena
- Truettner, L.H. and Deyarmond, A.B. (1949). *Unidentified Aerial Objects Project “Sign”*. Intelligence Dept., Air Material Command, Dayton, Ohio.
https://ia800209.us.archive.org/14/items/ProjectSIGN/Project%20SIGN%20-%20Feb.%201949_text.pdf
- Turvey, M.T. and S. Kravetz. (1970). Retrieval from iconic memory with shape as the selection criterion. *Perception & Psychophysics*, Vol. 8 (3), p.172.
<https://doi.org/10.3758/BF03210198>
- UKMoD. (2000). *Project Condign: Unidentified Aerial Phenomena (UAP) in the UK Air Defence Region*. UK Ministry of Defence, U.K. Retrieved March 19, 2023 from <https://webarchive.nationalarchives.gov.uk/ukgwa/20121110115327/http://www.mod.uk/DefenceInternet/FreedomOfInformation/PublicationScheme/SearchPublicationScheme/UnidentifiedAerialPhenomenaUAPInTheUkAirDefenceRegion.htm>
- USAF. (1955). *Special Report 14, Analysis of Reports of Unidentified Aerial Objects, Project No 10073*. Aerospace Studies Institute, U.S. Air Force. May 5, 1955. Retrieved January 7, 2023 from <https://www.explorescu.org/post/special-report-no-14-analysis-of-reports-of-unidentified-aerial-objects-project-no-100073>
- USAF. (1970). *Project Blue Book and Project SIGN, 1947 – 1969*, microfilm, card file 1947.06, 9668731, Mt. Ranier, Washington, National Archives and Records Administration, Washington, D.C., Andrews AFB, MD. <https://www.archives.gov/research/military/air-force/ufos#geninfo>
- USAF. (1995). *Air Force UFO Fact Sheet*. United States Air Force. Retrieved January 13, 2023 from https://www.nsa.gov/portals/75/documents/news-features/declassified-documents/ufo/usaf_fact_sheet_95_03.pdf

- USAF. (2022, March 19). *Unidentified Flying Objects and Air Force Project Blue Book*. United States Air Force. Retrieved September 4, 2022 from <https://www.af.mil/About-Us/Fact-Sheets/Display/Article/104590/unidentified-flying-objects-and-air-force-project-blue-book/>
- U.S. Senate, (2023). Hearing to receive testimony on the mission, activities, oversight, and budget of the all-domain anomaly resolution office. *U.S. Senate Subcommittee on Emerging Threats and Capabilities*, Wednesday, April 19, 2023. Accessed 2022/09/25 https://www.armed-services.senate.gov/imo/media/doc/23-31_04-19-2023.pdf
- Weinstein, D. F. (2012) Aviation safety and unidentified aerial phenomena: Preliminary study of 600 cases of unidentified aerial phenomena (UAP) reported by military and civilian pilots, *NARCAP International Air Safety Report IR-4* http://www.uapreporting.org/wp-content/uploads/2012/12/narcap_IR-4_DWeinstein_NEW_3-21-12.pdf accessed 2023/09/16.
- Westheimer, G. (1979). The spatial sense of the eye. Proctor lecture, *Invest. Ophthalmol. Vis. Sci.* 1979;18(9):893-912. <https://iovs.arvojournals.org/article.aspx?articleid=2175912>
- Zeidman, Jennie. (1991). I Remember Blue Book. *International UFO Reporter*. March/April 1979; 16 (2):7-12, 23. Retrieved March 21, 2023 from <https://project1947.com/articles/jzbluebook.htm>